



'ATHEN'

PERGOLA 8'X8'



** LES RIDEAUX SONT VENDUS SÉPARÉMENT
** CURTAIN ARE SOLD SEPARATLY

25

service@durahousewares.com

1-888-288-3872

#34400 #34401

Instruction générale « abris solaires »

* L'assemblage de cette structure peut prendre de deux à quatre heures. Assurez-vous de prévoir suffisamment de temps pour pouvoir terminer et au moins deux à trois personnes sont nécessaires pour un assemblage en toute sécurité. Ne laissez pas la structure inachevée pendant la nuit (cela pourrait endommager l'abri soleil).

* Avant de commencer l'assemblage, assurez-vous que toutes les pièces sont présentes et en bon état en utilisant la liste des pièces fournie dans ce livret.

* Si la boîte est endommagée, prenez des photos des dommages, du numéro d'article et du numéro de bon de commande que vous trouverez sur la boîte elle-même.

* En cas de pièces manquantes ou endommagées, vous pouvez contacter notre service après-vente du lundi au vendredi de 9h00 AM à 16h00 PM au (450) 622-3872 ou sans frais (1-888) 288-3872 ou par courriel à service@durahousewares.com

* Cet abri-soleil doit être monté sur un sol plat.

* Pour une installation facile, veuillez suivre les instructions étape par étape, si vous rencontrez des difficultés, n'hésitez pas à nous appeler pour obtenir de l'aide, pour certains de nos produits, nous avons des vidéos d'installation qui pourraient vous aider.

* Ne serrez aucune vis jusqu'à ce que l'appareil soit complètement monté.

* Vérifiez et serrez toutes les vis régulièrement par la suite

Pour un service plus rapide, soyez prêt à nous fournir:

1. Preuve d'achat
2. Numéro d'article et PO # (tous deux indiqués sur la boîte).
3. En cas de pièces endommagées, photo de la pièce endommagée et une photo de la boîte (en cas de dommages visibles).
4. Si vous nous contactez par courriel, veuillez inclure votre numéro de téléphone afin que nous puissions vous rappeler.

General instruction “sun shelters”

* The assembly of this structure may take two to four hours to complete. Please make sure you allow enough time for completion, at least two to three people are required for safe assembly, do not leave the structure unfinished overnight (may result in damage to the unit).

* Before beginning the assembly make sure all parts are present and in good condition using the parts least provided in this booklet.

* If you detect damages on the box itself, take pictures showing the damages, the item # and PO # indicated on the box.

* In case of missing or damaged parts you can contact our service department Monday to Friday from 9:00 AM to 4:00 PM at (450)622-3872 or toll free

(1-888)288-3872 or by email at service@durahousewares.com

For faster and better service please be ready to provide us with:

1. Proof of purchase

2. Item # and po # (both indicated on the box).

3. In case of damaged parts, photo of the damaged part and a photo of the box (in case of visible damage).

4. If you contact us by email, please include your phone # so we can call you back.

* This unit must be mounted on level ground.

* For easy installation please follow the instruction step by step, if you encounter difficulty don't hesitate to call us for support, for some of our products we have installation video's that might help.

* Do not tighten any screws until the unit is fully mounted.

* Check and tighten all screws on regular basis.

AVERTISSEMENT PERGOLA

La structure du toit de cette pergola n'est pas conçue pour supporter du poids, pour cette raison, nous recommandons fortement le retrait des ardoises de toit (partie « O ») pour l'hiver.

Si vous décidez de garder le toit sur la Pergola, il est très important que vous gardiez les ardoises du toit en position ouverte pour éviter toute accumulation de neige sur le toit.

Le non-respect de cette instruction entraînera des dommages à la structure et un éventuel effondrement du toit.

N'oubliez pas qu'un toit effondré n'est pas sous garantie.

Lorsque vous positionnez votre structure, assurez-vous qu'elle soit au moins à quatre pieds de tout mur (pour éviter l'accumulation de neige contre le mur ou la possibilité qu'une grande quantité de neige ou de glace glisse de votre toit de maison sur la Pergola).

Pour faciliter l'assemblage de ce produit veuillez appeler au 1-888-288-3872 ou par courriel service@durahousewares.com, nous vous donnerons un lien pour le vidéo d'assemblage.

WARNING PERGOLA

The roof structure of this pergola is not designed to hold any weight. Therefor we strongly recommend removal of the roof slates (part "O") for the winter.









If you decide to keep the roof on the Pergola, you must keep the roof slates in open position to prevent any accumulation of snow on the roof.

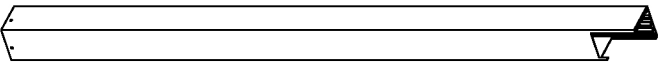
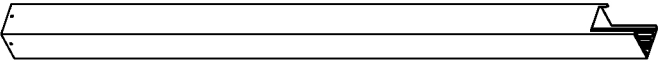





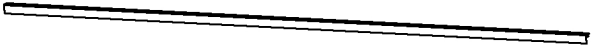
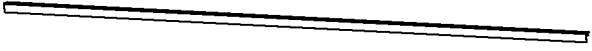
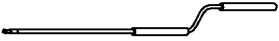

Failure to follow this instruction will result in damage to the structure and possible collapse of the roof.

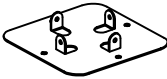
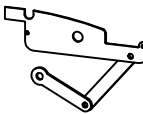



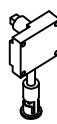





Remember collapsed roof is not under warranty.

When positioning your structure make sure it is at least four feet away from any wall (to avoid accumulation of snow against the wall or the possibility that a large amount of snow or ice that might slide from your home roof on to your Pergola).

To ease assembly for this item, please call Service at (1-888)288-3872 or e-mail us at service@durahousewares.com we will link you to assembly video.

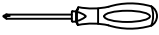
A		2
A1		2
B		1
B1		1
C		2
E		14
F		1
G		2
G1		2
H		1
I		1

L		4
M		1
M1		27
N		28
O		4
P		1
R		14
S		56
T	 4.2*18	112

T1	 5*15	8
U	 M6*15	17
V	 M6*45	4
V1	 M5*15	16
W		1
W1		1
W2		1
X		1
X1		14
Z		4

step/étape 1

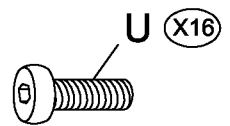
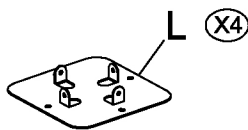
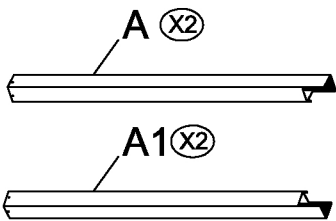
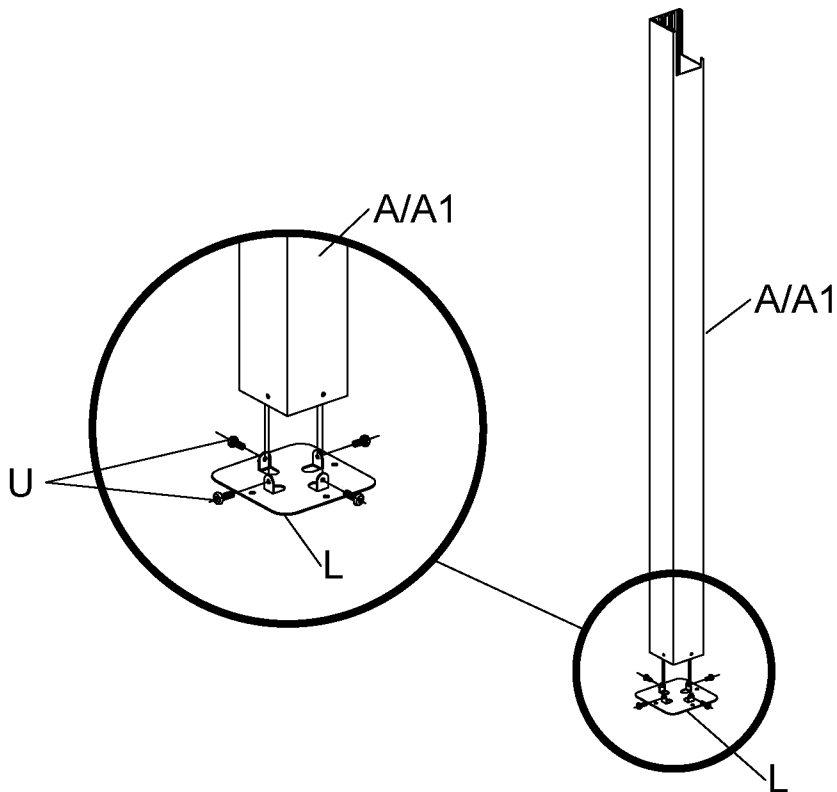

step/étape 2

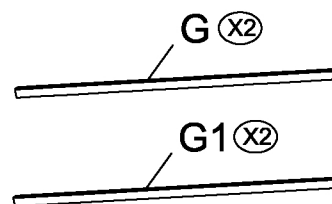
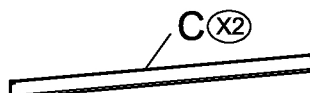
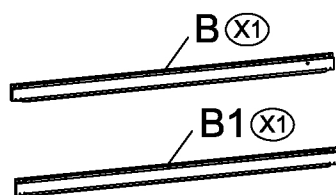
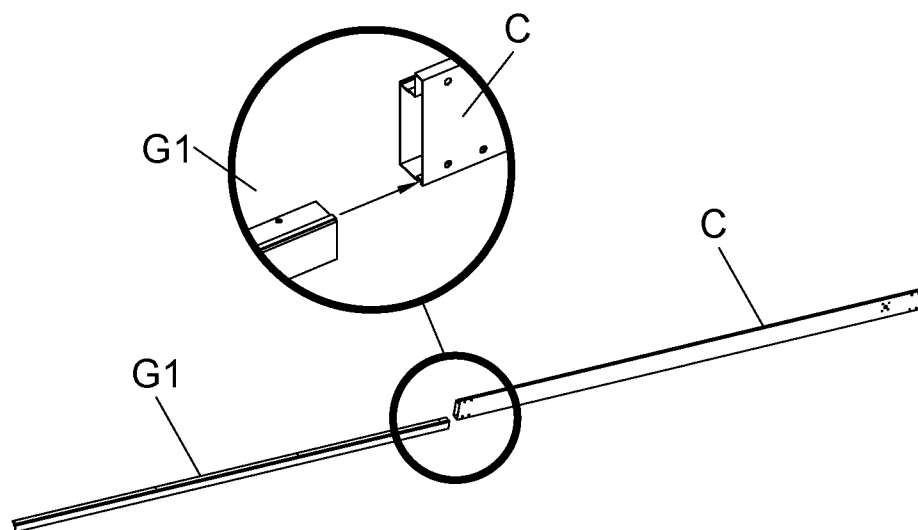
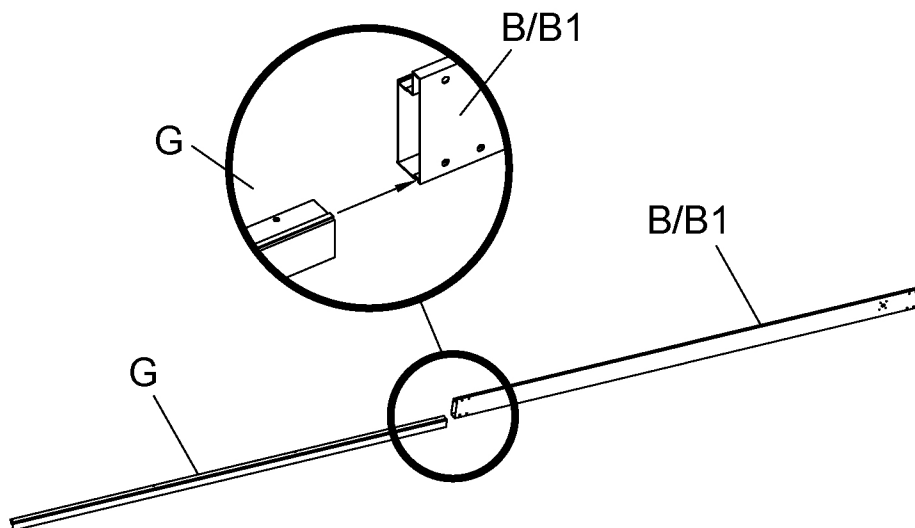

step/étape 3

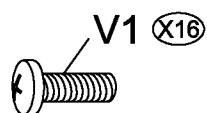
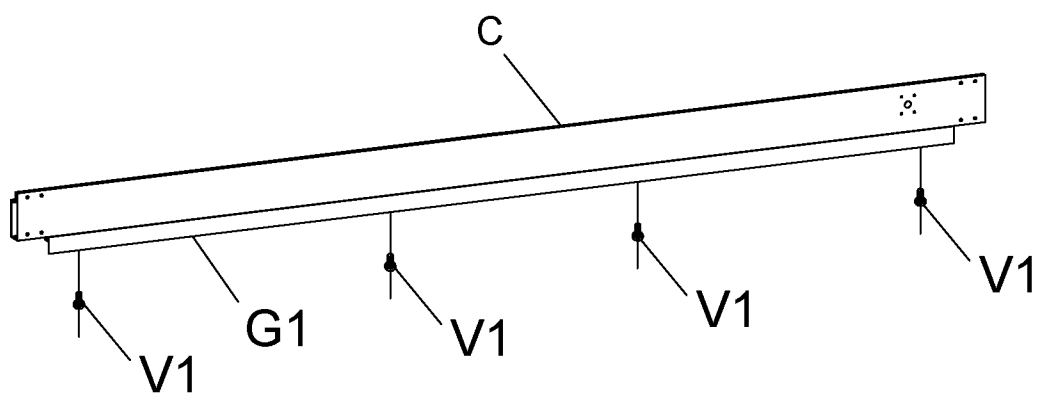
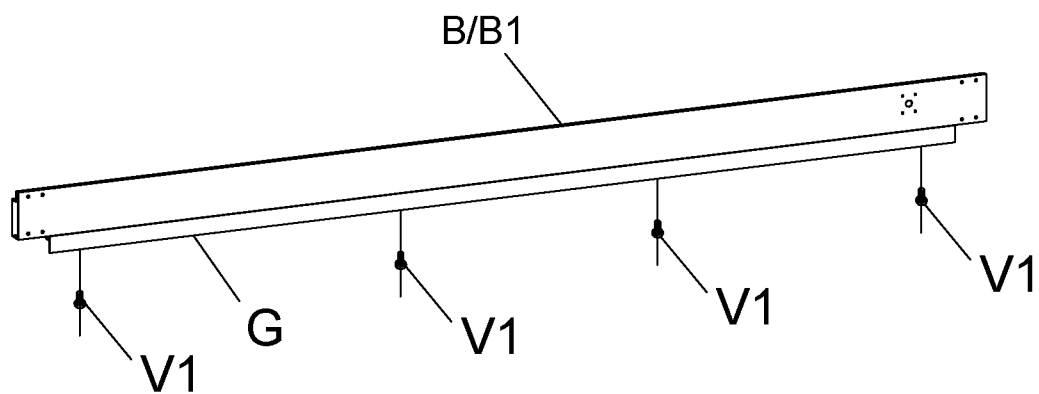

Step 4

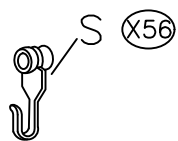
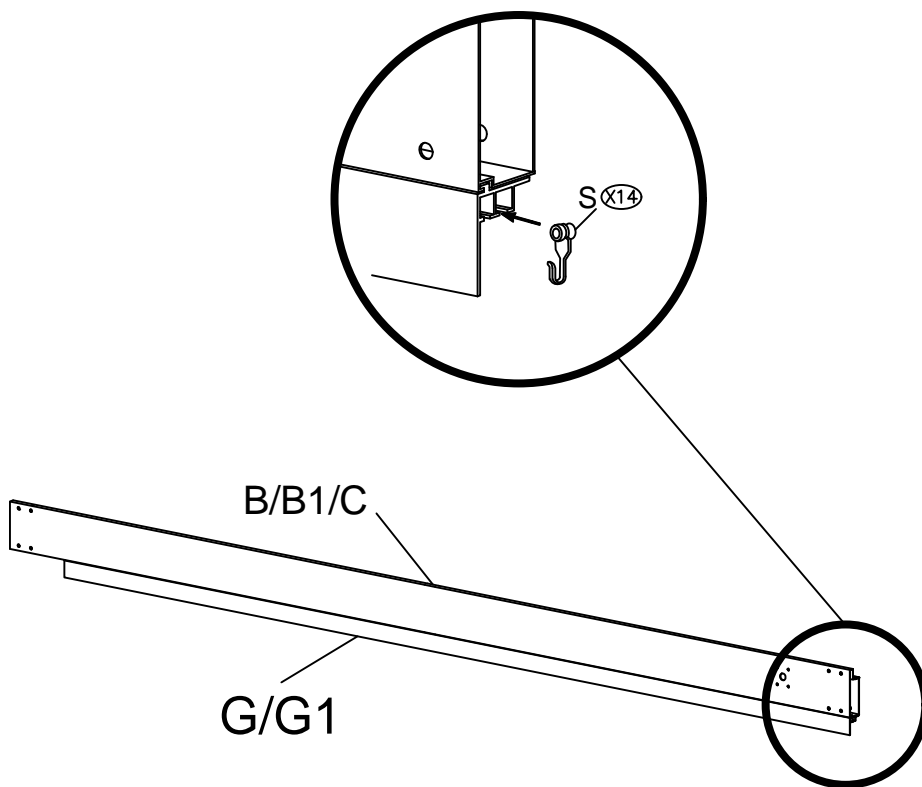

step/étape 5

In order to insert B/B1 into A/A1, screws must be loose. Don't forget to tighten once the piece is in place. / Afin d'insérer la pièce B/B1 dans la pièce A/A1, le vis doivent être partiellement desserrées. N'oubliez pas de serres bien les vis une fois la pièce A/A1 est en place.

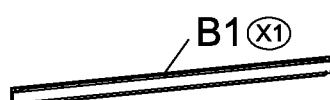
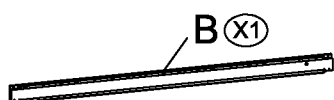
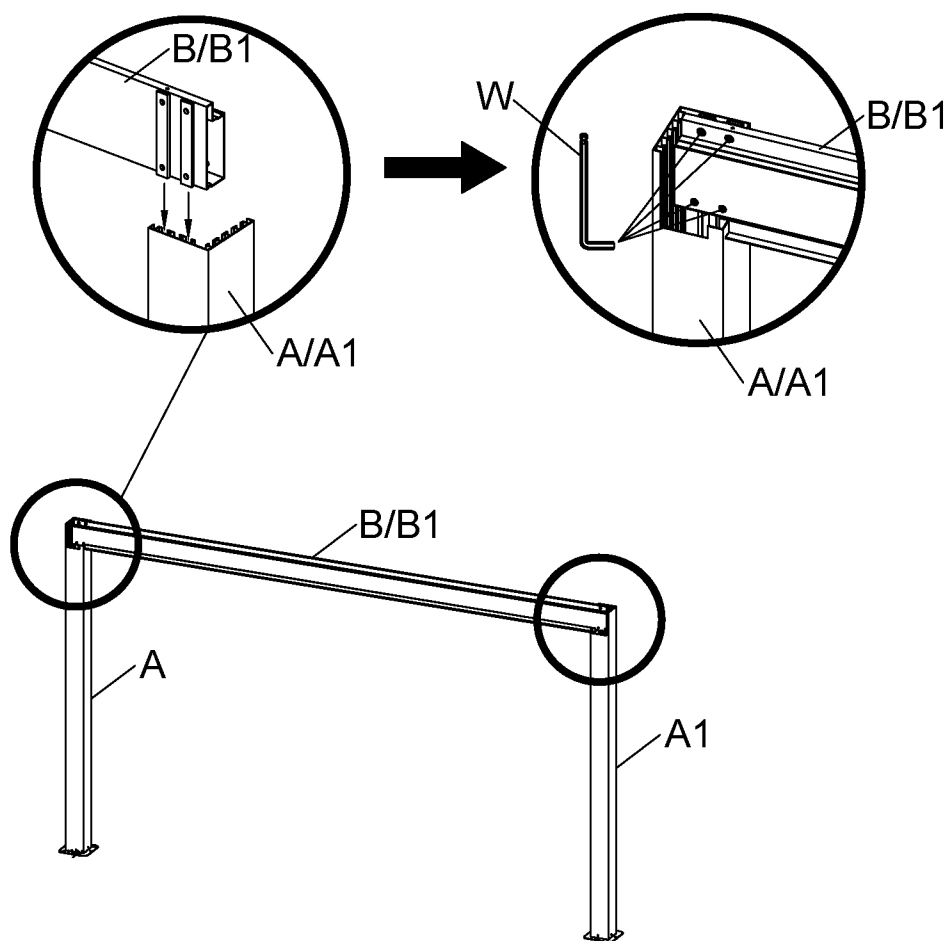

step/étape 6

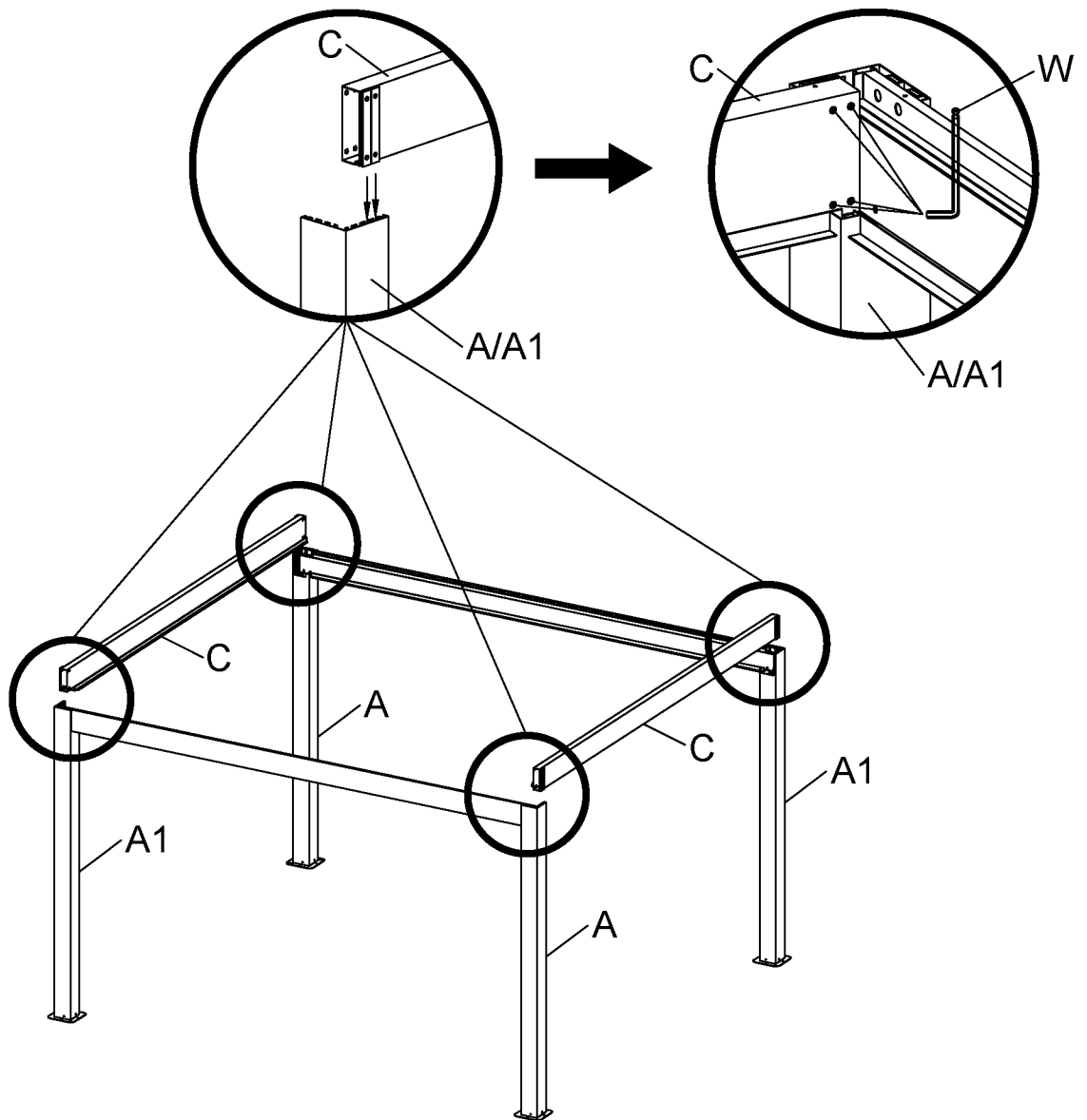

In order to insert B/B1 into A/A1, screws must be loose. Don't forget to tighten once the piece is in place. / Afin d'insérer la pièce B/B1 dans la pièce A/A1, le vis doivent être partiellement desserrées. N'oubliez pas de serres bien les vis une fois la pièce A/A1 est en place.

step/étape 7

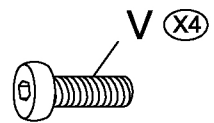
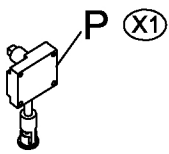
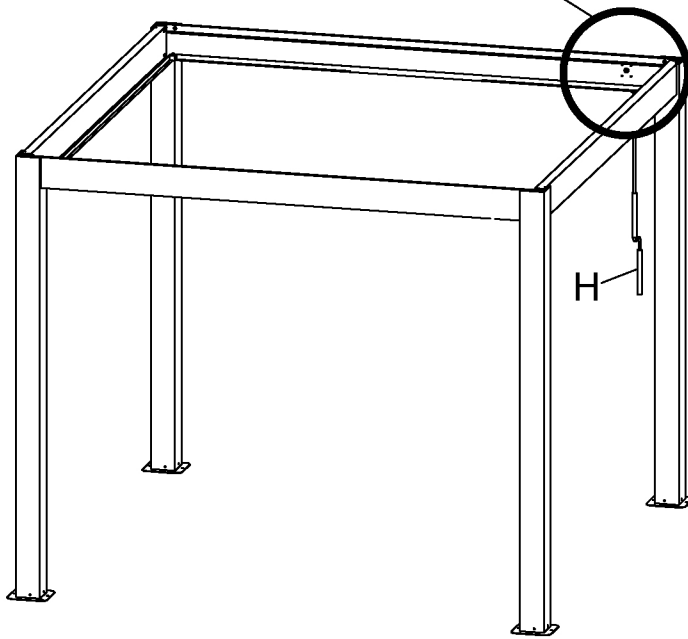
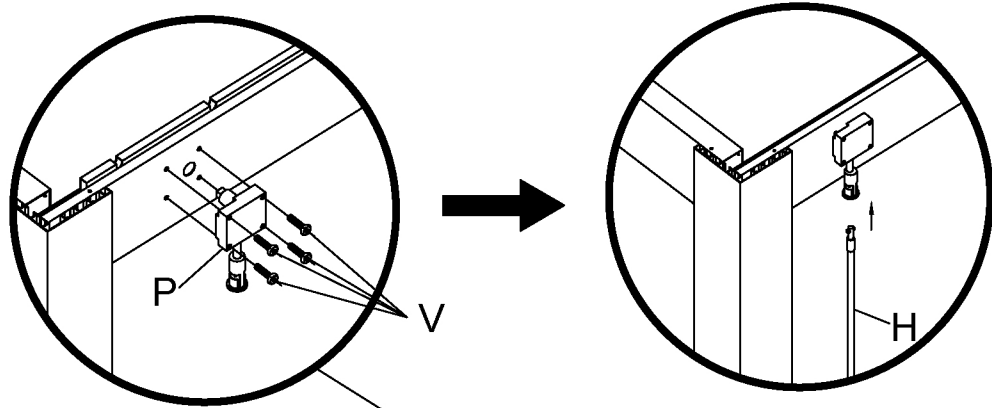

step/étape 8

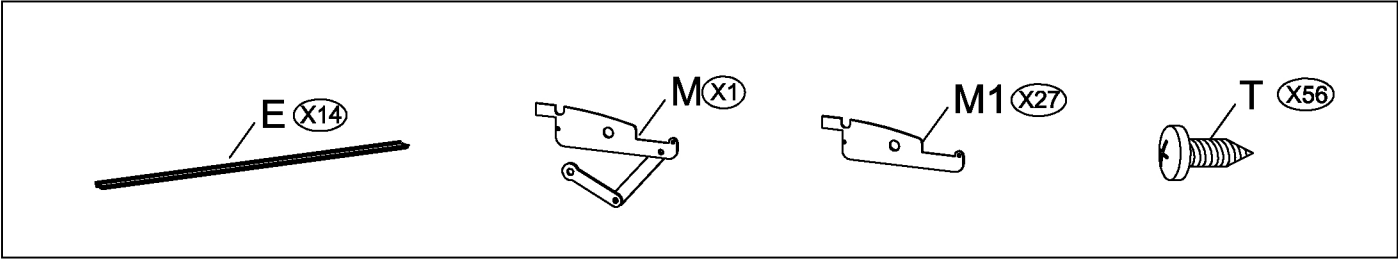
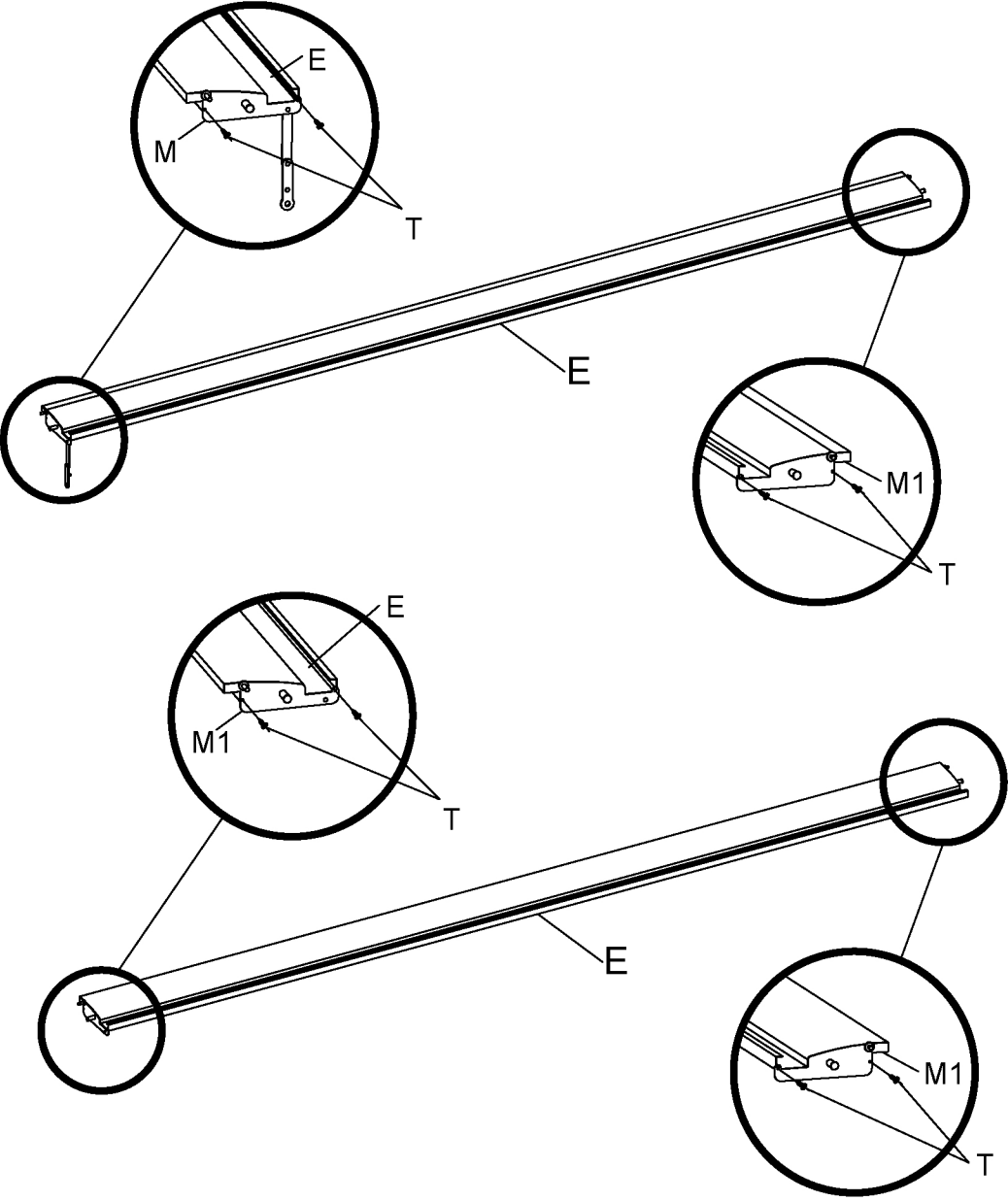

step/étape 9

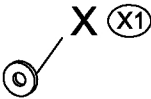
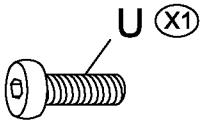
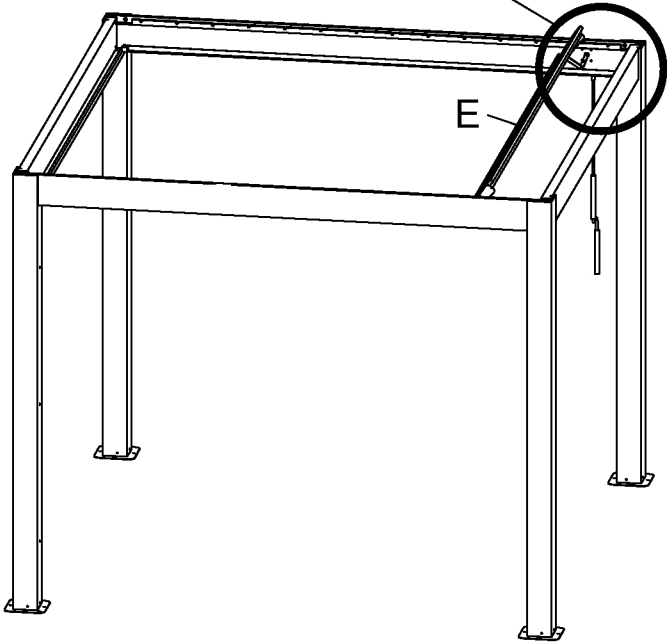
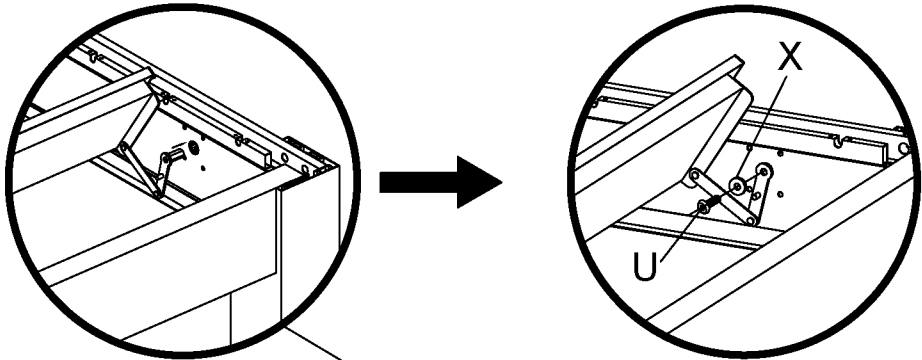

step/étape 10

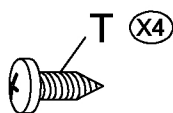
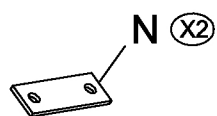
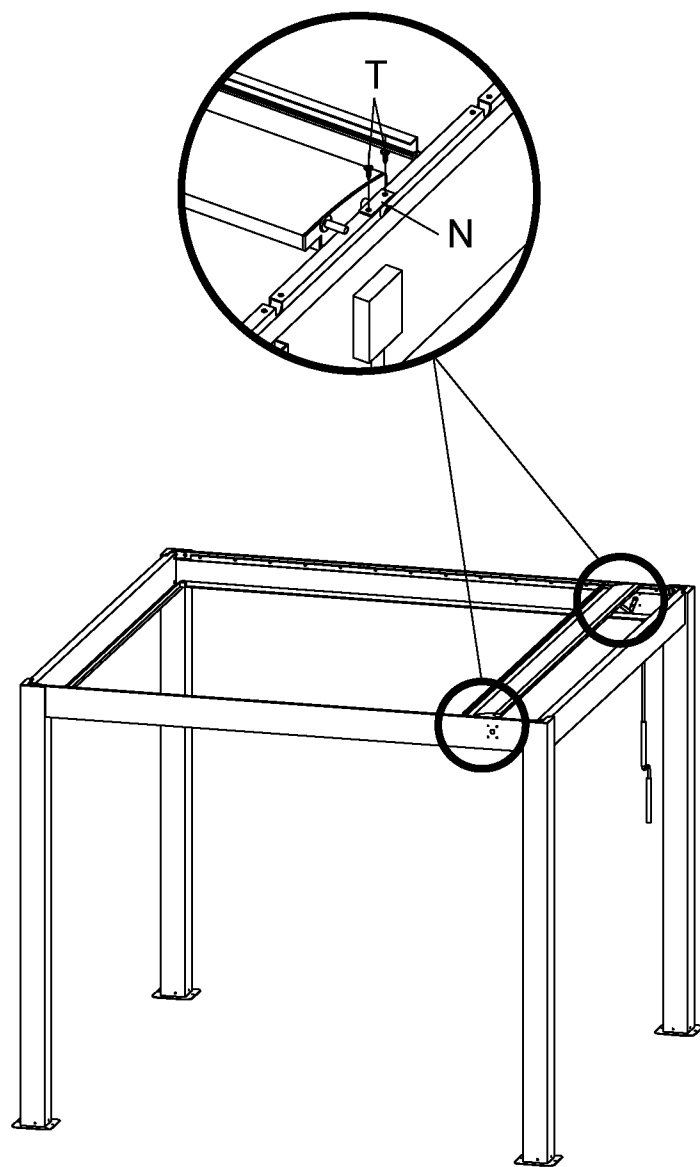

step/étape 11

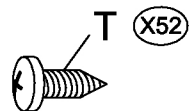
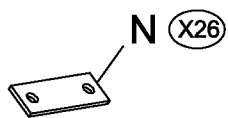
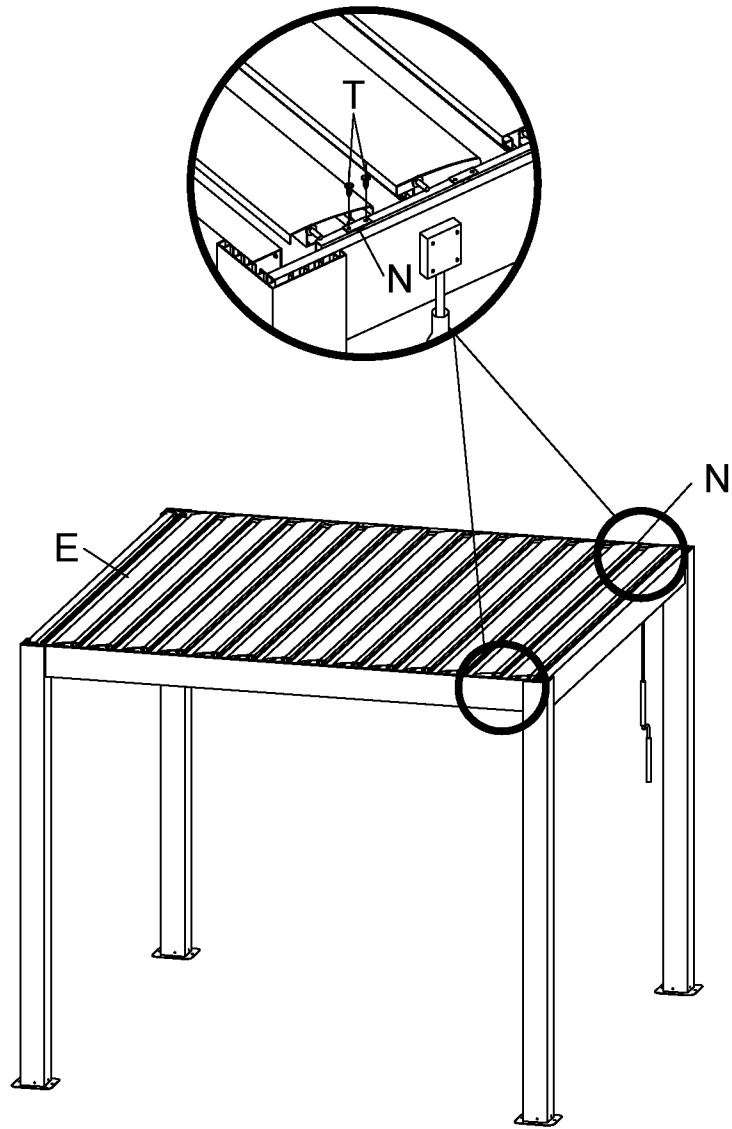

step/étape 12

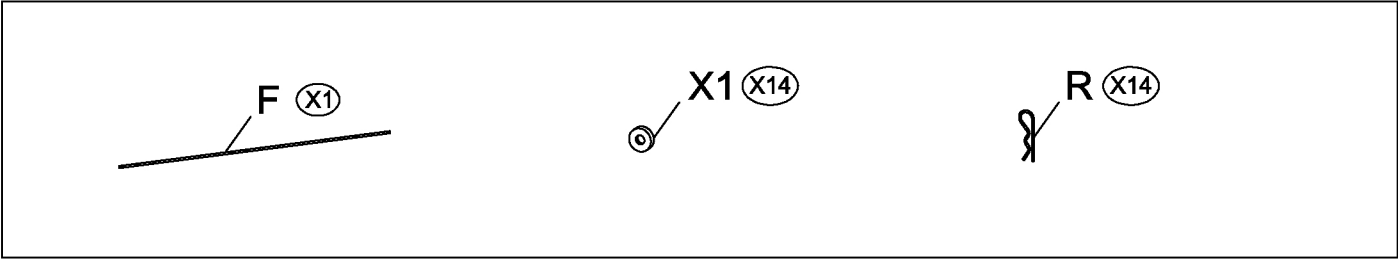
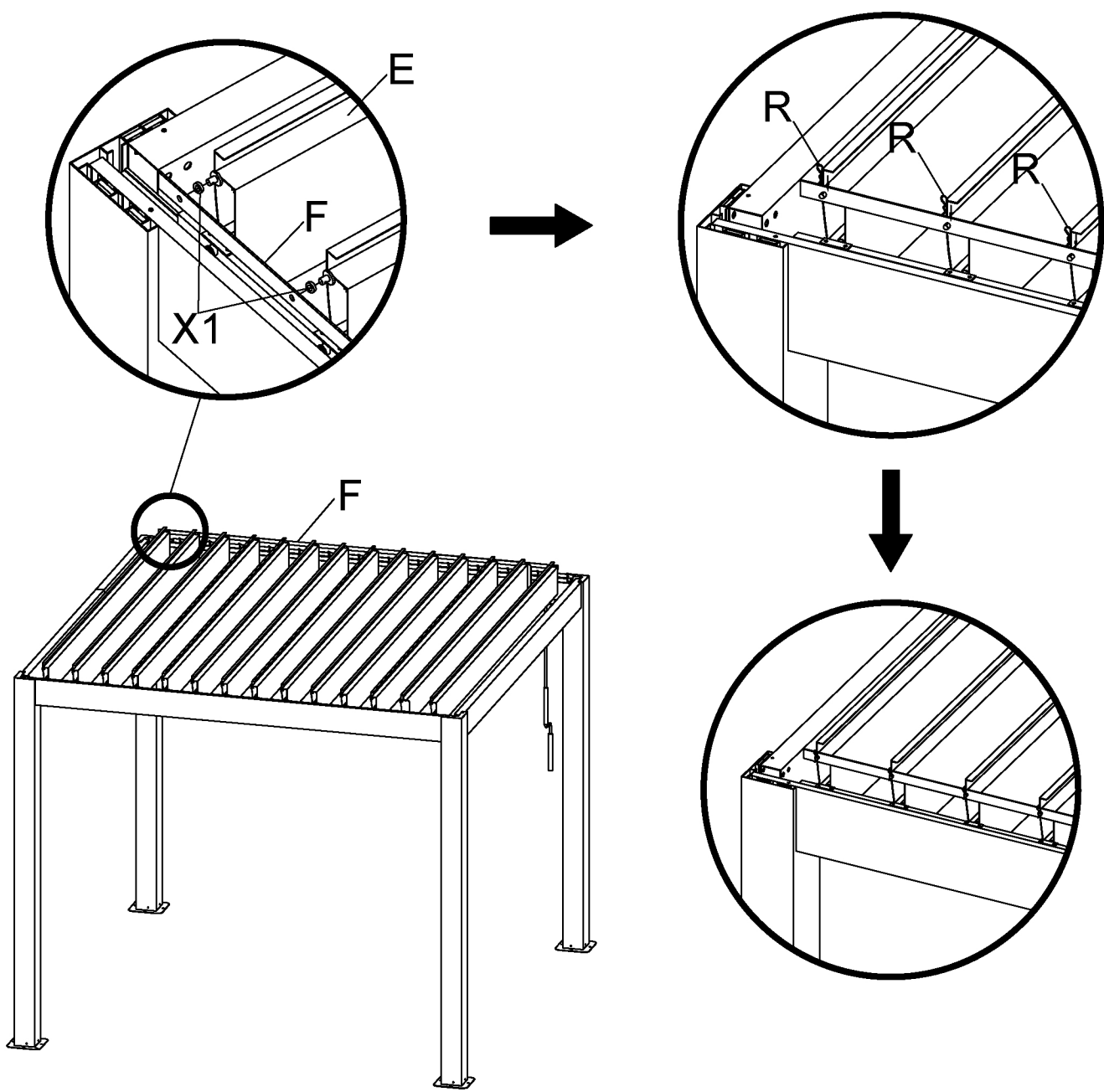

step/étape 13

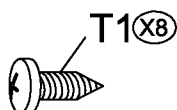
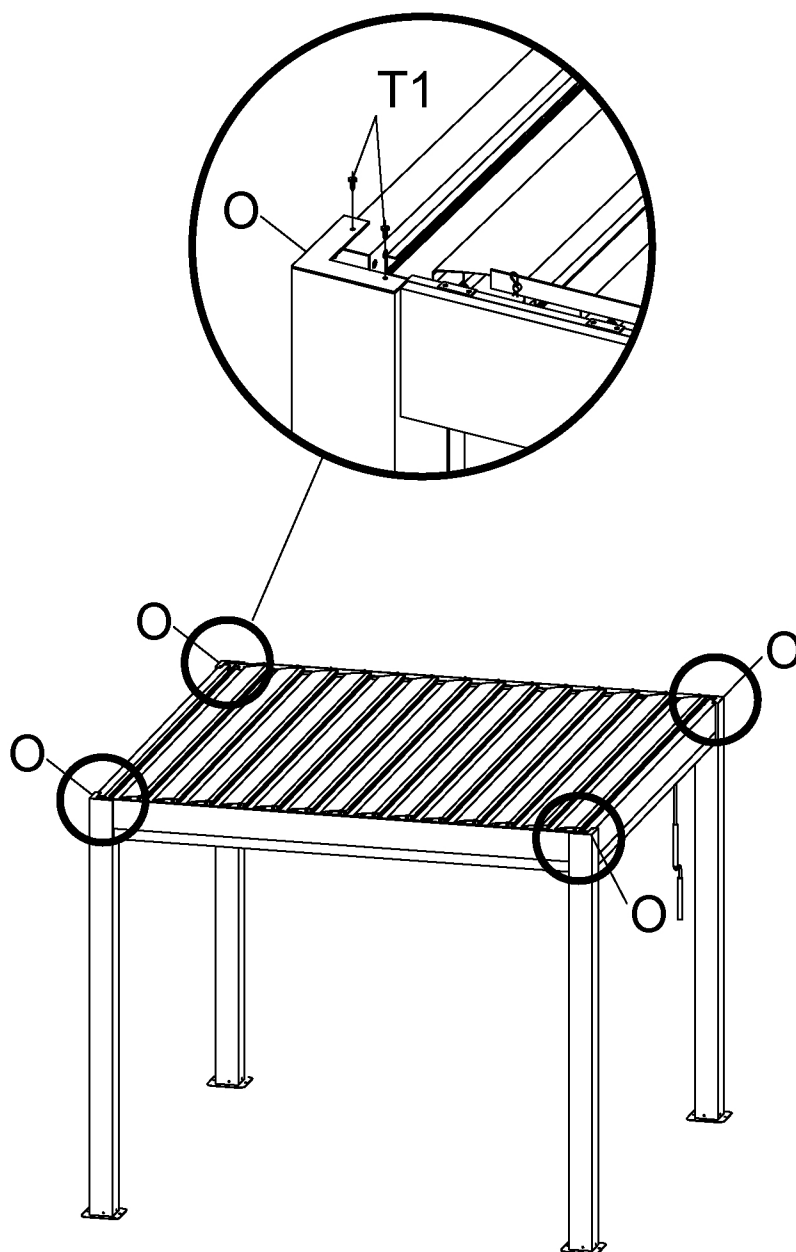

step/étape 14

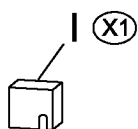
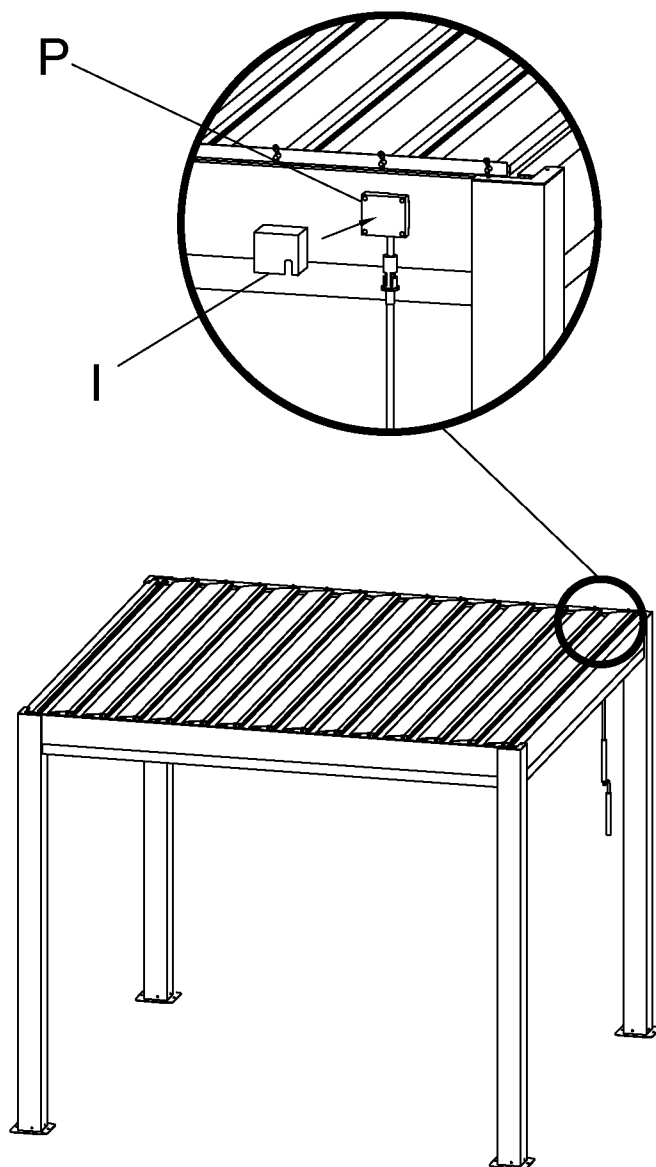

step/étape 15

